

KeyLink

by BuildingLink™

PRODUCT SPECIFICATIONS & SETUP GUIDE



TABLE OF CONTENTS

KeyLink PC System Requirements	3
KeyLink Drawer Specifications	4
KeyLink Components	5
KeyLink 140-Drawer Cutsheet	6
KeyLink 224-Drawer Custsheet	7
KeyLink Setup Instructions	8
KeyLink Riveting Instructions	10
KeyLink Implementation: A Stage-By-Stage Guide	11
KeyLink How-To Videos	12
Using KeyLink	13
KeyLink Technical FAQ and Troubleshooting	16



DELL OPTIPLEX 3280 ALL-IN-ONE WITH TOUCH SCREEN

SPECIFICATIONS

- Intel Core i5-10500T
- 8GB 2666MHz DDR4 Memory
- M.2 128GB Solid State Drive
- 21.5" 1920x1080 Touch Screen
- Intel WiFi 6 AX200 2x2 (Gig+) + Bluetooth5

PORTS

- 6 External USB Ports
- 1 RJ-45 Port
- 1 DisplayPort 1.4 Output Port
- 1 Universal Audio Jack

DIMENSIONS

- Height w/o stand: 12.96" (32.94 cm)
- Height w/ fixed stand: 15.3"-23.5" (38.7 cm)
- Width: 19.6" (49.79 cm)
- Weight w/ stand: 15.27 lbs. (6.93 kg)

POWER

- 130W Integrated Power Supply Unit with Type B Electrical Plug

Due to the constant changes in technology hardware, if our KeyLink PC needs services/repairs or even a replacement in the future, we cannot guarantee that it would be the same model from your initial KeyLink installation.

Customers can choose to opt out on our included KeyLink PC and purchase their own PC. Please be sure that it meets the recommended system requirements (see right) to be compatible with the KeyLink software. A \$500 credit will reflect on the invoice after system delivery.

CUSTOMER-PROVIDED KEYLINK PC SYSTEM REQUIREMENTS

- Operating System: Windows 10 or newer (must be 64-bit version)
- CPU: Intel i3 or equivalent and higher
- Hard Drive: 120GB or more (SSD recommended)
- RAM: 4GB or more (8GB recommended)
- Screen Size: 17-inches (19" or larger recommended)
- Touchscreen: Touch interface is not required but can provide optimal user experience
- Optional: Drill a hole/grommet on the desk for cables to pass through.

Our Support Staff cannot service or repair any PCs or peripherals not provided by BuildingLink.

KEYLINK DRAWER SPECIFICATIONS



140-KEY DRAWER

DIMENSIONS
20.8"D X 21.4"W X 7.6"H
WEIGHT
45 LBS WITHOUT KEYS & TAGS

224-KEY DRAWER

DIMENSIONS
30.3"D X 21.4"W X 7.6"H
WEIGHT
65 LBS WITHOUT KEYS & TAGS

Every KeyLink System includes:

- KeyLink Software
- BuildingLink Integration / Connector for BuildingLink
- All-In-One Touch Screen Computer
- Heavy Duty Fingerprint Scanner
- SmartTags, Rivets, and Rivet Gun
- Drawer Power Cord, USB Cable, and USB Hub
- L-Brackets and U-Brackets for Securing Purposes
- Manual Override Key (to unlock the back of the drawer in case of a power outage)
- Red Emergency Key Fob (for access in case of a drawer disconnect mode)
- Domestic Shipping & Handling (International Shipping and Customs Clearance at Additional Charge)
- Worldwide Remote Installation and Training

KEYLINK INSTALLATION RECOMMENDATIONS

- Be sure to allow some wiggle room to get the system into the space and run the cabling from drawer(s) to PC.
- Power Requirement: the KeyLink system (drawer & PC) uses the US standard 110/220/240 volts for power cords to the drawers and PC and we will provide the proper power cables for your region if necessary, so no adapter or power converter is needed.
- Below are some useful links for your reference:
Website - www.keylinkusa.com
Customer Support - support@buildinglink.com / 877-501-7117 ext. 0
Online Help Database - help.buildinglink.com/using-keylink

KEYLINK COMPONENTS

STANDARD KEYLINK COMPONENTS



KeyLink PC



KeyLink Drawer
(rear view)



Fingerprint
Reader



USB Hub



SmartTags



Rivets



Emergency FOB



Manual
Override Key



KeyLink
Transporter



Backup Drive



Power Cord



USB Cable



Rivet Gun



Rivet Cutter

OPTIONAL KEYLINK COMPONENTS



Signature Pad



Web Cam



SmartBoxes

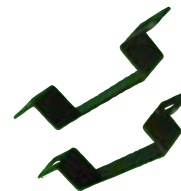

U-Brackets



L-Brackets

KEYLINK 140-DRAWER CUTSHEET

5 ROW DRAWER DIMENSIONAL DRAWING MARCH 01, 2017

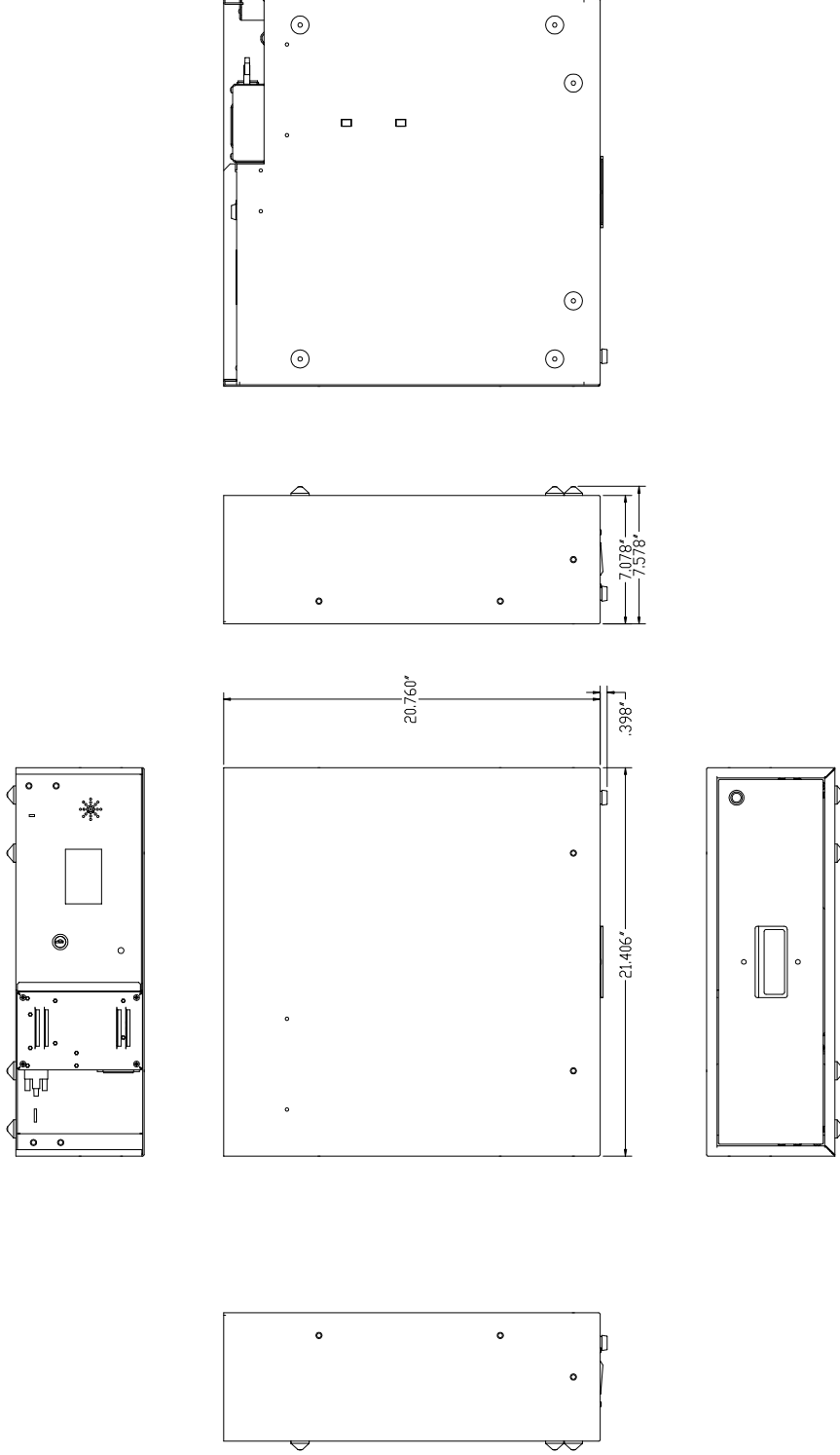

KEYLINK 224-DRAWER CUTSHEET

8 ROW DRAWER DIMENSIONAL DRAWING
MARCH 01, 2017

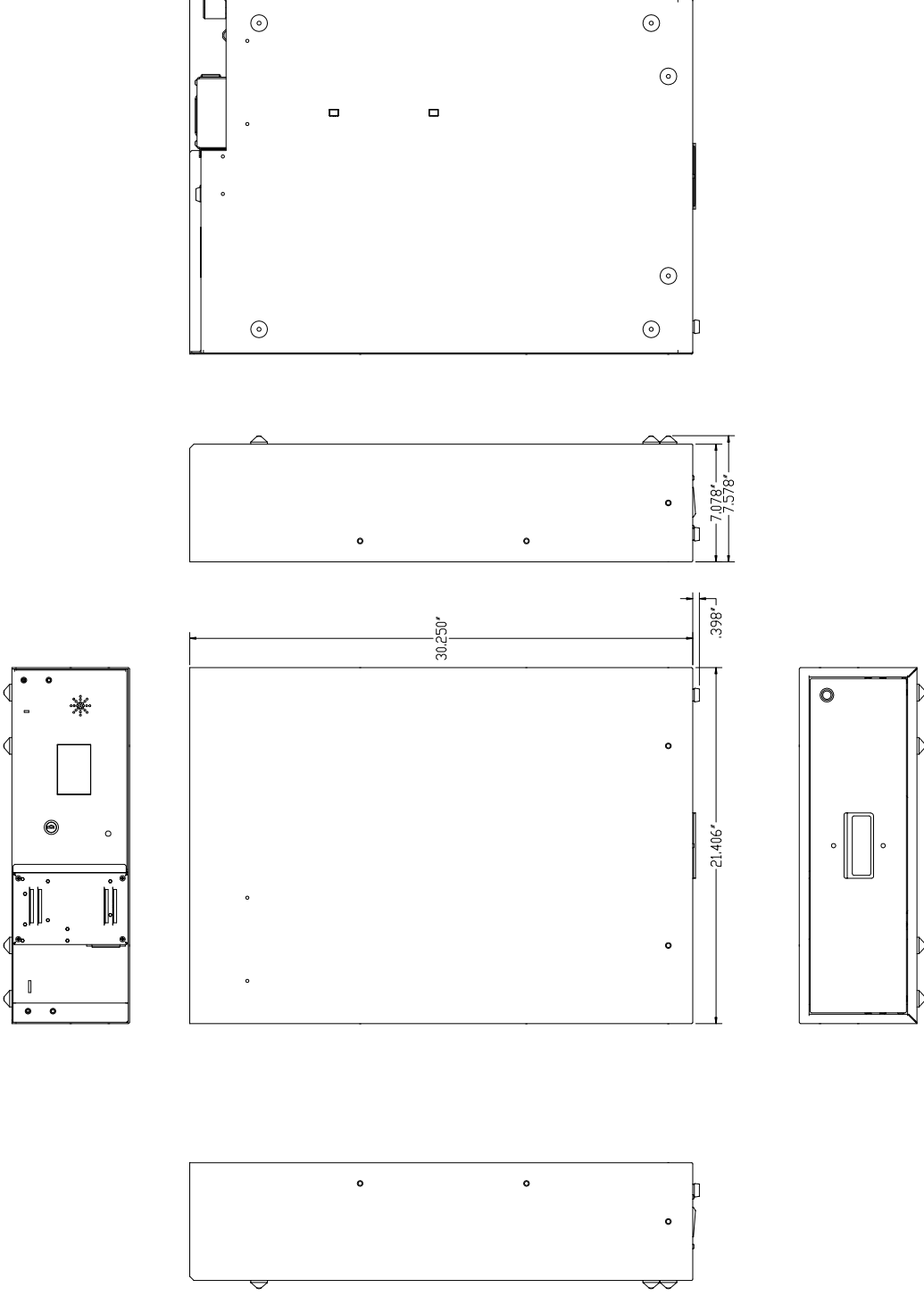

KEYLINK SETUP INSTRUCTIONS

STEP 1

Unbox your KeyLink drawer(s) and PC packages.

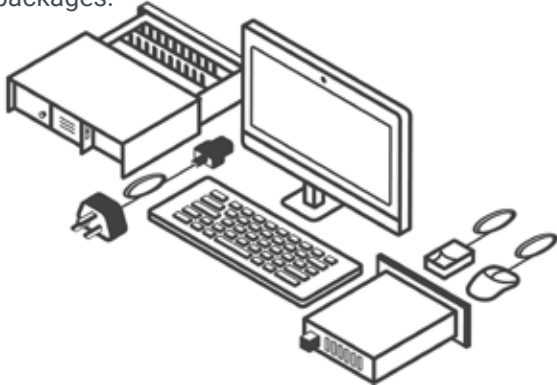

STEP 2

Plug one end of the included power cord to the back of each drawer.

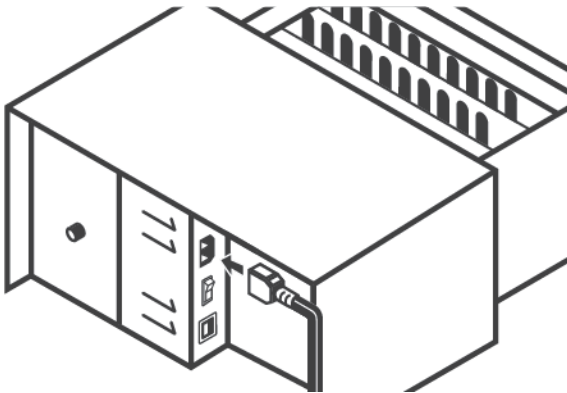

STEP 3

Plug the other end to a power outlet.

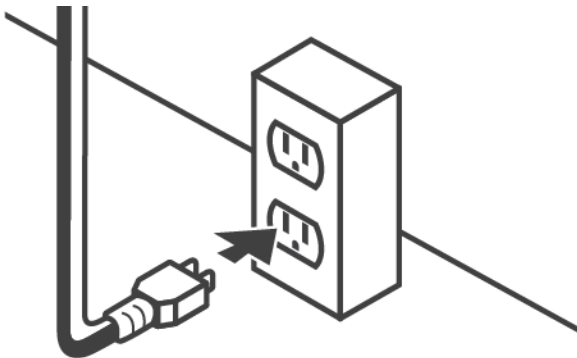

STEP 4

Plug one end of the included USB cable to the back of each drawer.

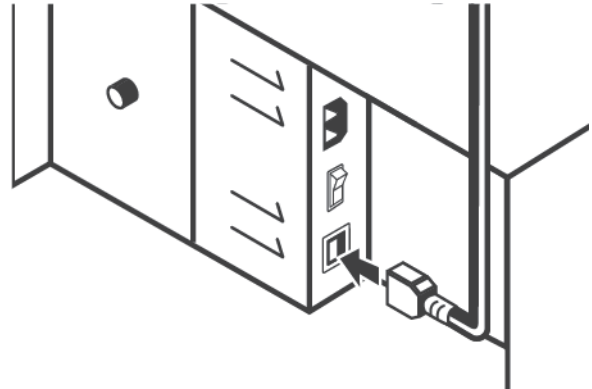

STEP 5

Plug the other end to either the included USB Hub,

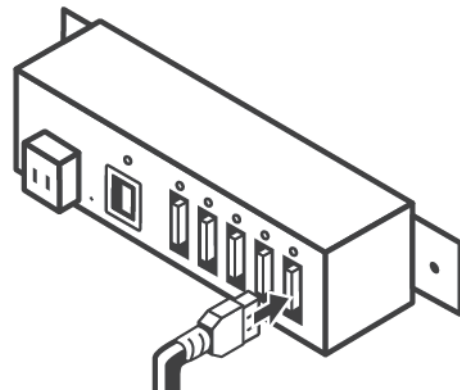

OR...

You can plug the other end directly to the PC.

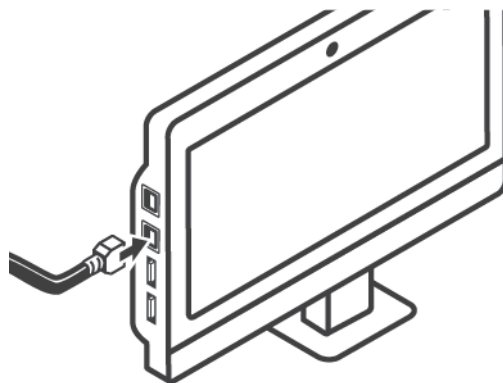

KEYLINK SETUP GUIDE

STEP 6

If you're using the USB Hub as an intermediary between the drawer(s) and PC; then plug the provided USB cable between the hub and the PC (please remove the screws on the sides when plugging into the PC).

STEP 7

Flip the powerswitch on the back of the drawer to the 'ON' position.

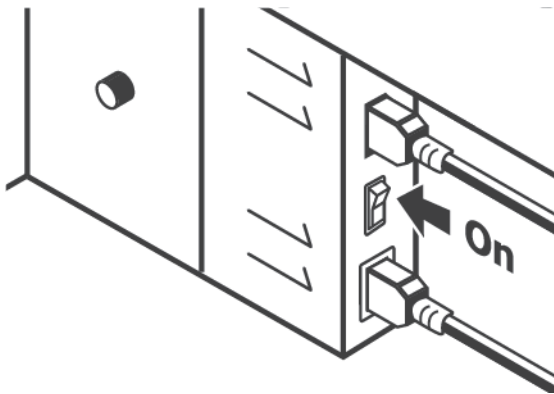

STEP 8

Power on the PC and connect it to your Internet via WiFi or Ethernet cable.

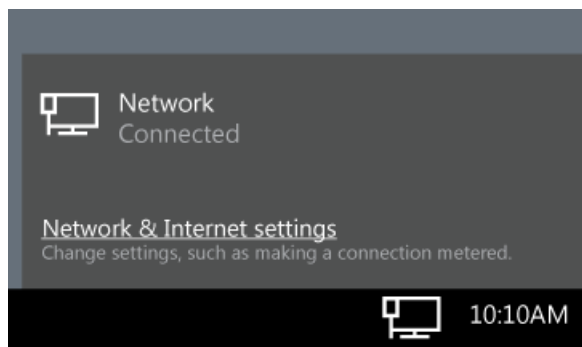

STEP 9

Please contact one of our team members at 877-501-7117 ext. 0 or support@buildinglink.com and they will assist you with the remote access points and software setup of KeyLink.



STEP 10

If needed, [please watch our online installation manual video](#) for a demonstration of the above setup steps.



STEP 11

Once everything is connected, please contact a KeyLink rep to schedule your telephone KL software configuration and training (also available in this setup guide under the section "Using KeyLink" or [online here](#) - KeyLink & BuildingLink Online Help Library if you wish to proceed with this step at your own convenience).

KEYLINK RIVETING INSTRUCTIONS

STEP 1

Place provided tag, rivets, and key(s) together tightly as shown on the right. Keys should be on the right side of the tag where it indicates “Keys on this side.”

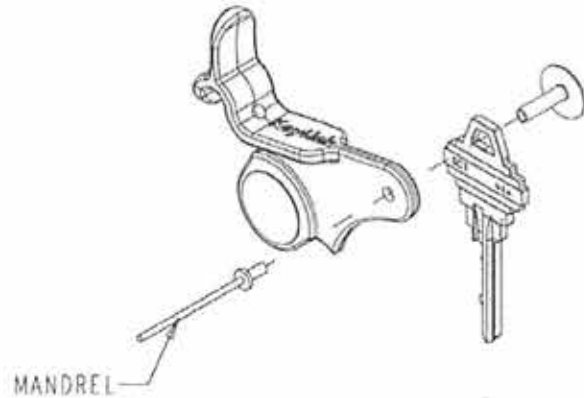

STEP 2

Using the provided rivet gun, grip the mandrel and fasten both rivets together as shown on the right.



STEP 3

Installed tags should look like the images shown here, with keys on the right side of the tag, where it indicates “Keys on this side.”

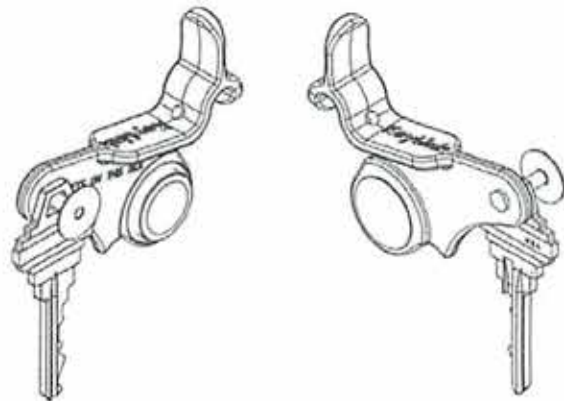

KEYLINK* IMPLEMENTATION: A STAGE-BY-STAGE GUIDE

STAGE	YOU WILL...	KEYLINK WILL THEN...
Customer Order	<ul style="list-style-type: none">• Confirm that the drawer quantity and sizes on the Customer Order meet your needs and your space constraints.• Sign the customer order and email or fax it back to us.	<ul style="list-style-type: none">• Contact you to answer any questions you may have, and to learn what your install timetable needs are. (Typical deliveries are done 2-3 weeks from order date.)• Set aside from our inventory and allocate to your job the drawer(s) you have ordered.• Send you an invoice, to be paid upon installation.
Pre-Installation	<ul style="list-style-type: none">• Prepare your front desk, cabinet, or closet space where the drawer(s) will be placed. Make sure you have adequate depth to accommodate the drawer sizes you have ordered (22" or 31"), and a working internet connection and power outlet.	<ul style="list-style-type: none">• Schedule with you an approximate delivery date.• As the date approaches, we will calibrate and prepare your system and peripherals for delivery.
Installation	<ul style="list-style-type: none">• Confirm that you are ready for installation, and will have the necessary staff available for a basic training.• If converting from an old KeyTrak system, all of your keys should already have been transferred to their new SmartTags.	<ul style="list-style-type: none">• Assemble and connect the drawer(s) and peripherals and turn your system on (or guide you through doing the same, if this is a remote install).• We will also provide basic training on how to operate the system including how to set staff permissions, register new keys, remove and return keys. You will be left with a working system.
Training	<ul style="list-style-type: none">• Call us within the next few days, to schedule a more complete training, at a time and place when most of your staff will be able to attend. This is also a good time to pay the invoice you have received.	<ul style="list-style-type: none">• Provide a 30-45 minute KeyLink training for managers and staff. Instruct the staff on how to navigate the program, remove/return keys, check reports, and take advantage of the integration processes between KeyLink and BuildingLink that occur in the background.• Address any other questions you may have.
Manager/Staff Utilization	<ul style="list-style-type: none">• Continue to use KeyLink for all key removals and returns, for viewing the keymap of drawers or the activity log, thereby creating a fully-documented audit trail of all key activity.	<ul style="list-style-type: none">• Provide continuous remote monitoring of your system's ability to connect over the internet to sync with BuildingLink.• Be available for ongoing technical support or questions at support@buildinglink.com or 212-501-7117 ext. 0.

* Includes: KeyLink Software, KeyLink Connector for BuildingLink, Touch Screen Computer, Heavy Duty Fingerprint Scanner, SmartTags, Rivets & Rivet Gun, Domestic Shipping & Handling, Remote Installation
140-Key Drawer Dimensions: 20.8"D x 21.4"W x 7.6"H / 224-Key Drawer Dimensions: 30.3"D x 21.4"W x 7.6"H

KEYLINK HOW-TO VIDEOS

We have a collection of informative videos to help you get up and running with your KeyLink system.

To view these videos on your smartphone or tablet: Use your smartphone/tablet camera or QR Code Reader app and scan the QR Code below to launch the video on your device.

To view these videos on your computer or laptop: Click on the "Play" icon at the center of each image. This will launch your browser with the video you've selected.



KeyLink - An Introduction



Unboxing and Connecting the KeyLink System



Rivet Installation



Using KeyLink Software

This page will guide you through how to use the KeyLink system. If you have any issues while using the system, please refer to our Technical FAQ and Troubleshooting page or contact BuildingLink at support@buildinglink.com or call 877-501-7117.

QUESTION

How do I register my fingerprint?

ANSWER

Click the My Account button, log in with your BuildingLink username and password, select Fingerprint Management, and follow the instructions on the “Fingerprint Enrollment” screen. Choose the finger you wish to register, place that finger on the reader, and scan it four times. After each scan, you should see your fingerprint on the screen. Next, click Enroll. You’ll then be directed back to the previous page where you can register more fingers if you wish. Click Done when you’re finished.

QUESTION

How do I register a new key?

ANSWER

Touch the Key In button, and authenticate either by logging in, or using your fingerprint. The drawer will unlock. Open the drawer, and place the Keytag into an empty slot—DO NOT CLOSE THE DRAWER YET. Once a new keytag is placed into a slot, the “Register Key” screen will open; here you can assign the Keytag to a unit. You can also add a description of the keys on the tag. Both fields are searchable when looking for a key. Once done, close the drawer. (Note: you do not have to close the drawer after registering a key; if you want to register another key, simply place it into a slot and the “Register Key” screen will open.) See our video on how to use KeyLink for more information.

QUESTION

How do I unregister a key from the system?

ANSWER

To permanently remove a key from the system, you must unregister the key. If the key is still in the drawer, go through the key removal process, and choose Unregister Key as the reason you are pulling the key. Once the key is removed, a screen will open asking you if you are sure you want to unregister the key. Choose Yes. If the key is not in the drawer, you can select the key under the Keys Out section of the main screen. Choose Unregister Key. Once you choose Unregister Key, you will have to authenticate, and then confirm you wish to unregister the key. If a key that has been unregistered is returned to the system, the system treats it as a new key, and the “Register Key” screen will open.

QUESTION

How do I remove a key?

ANSWER

To remove a key, click the Key Out button. On the next screen, type in the apartment number of the key you are looking for and click on the key you wish to remove in the search box (note: selecting a key moves it to the right side of the screen). If you wish to remove another key for the same reason, then repeat the previous step and enter the next apartment number of the key you want. Click Next. Click on the reason that you are removing the key(s) and click Next. Type in the recipient's name, have the recipient sign on the signature pad (optional), and take the recipient's picture with the webcam (optional). Next, click the green Get Key button. This will open the authentication page. Log in with either your registered fingerprint or BuildingLink username and password. Once successfully authenticated, the drawer will unlock. Open the drawer and the requested key(s) will be lit; remove the key(s) and close the drawer to complete the transaction.

QUESTION

How do I return a key?

ANSWER

To return a key, click the Key In button. This will open the authentication page. Log in with your fingerprint or BuildingLink username and password. Once authenticated, the drawer will unlock. Place the key into any empty slot and listen for the beep; also make sure that the screen says "Key Returned." Close the drawer to complete the transaction.

QUESTION

How do I register the red emergency fob?

ANSWER

Every KeyLink system comes with a red fob, which is your system's emergency key fob to unlock your KeyLink drawer(s) in case of a drawer disconnect event or a system error where you'll need to access the drawer(s) manually, but power is still on.

Simply tap the red fob to the round button reader in front of the drawer to unlock and open it to remove/return keys as needed until your system is running normally again.

To activate the red emergency key fob, simply click on the My Account button on the KeyLink dashboard/home screen, log in with your fingerprint or your BuildingLink username and password, and select Register Key Fob. Tap the key fob to the round button reader in front of the drawer, so that it can register the serial number of the fob and enter a four digit PIN code to complete the activation process. Click Save and Done to exit. Then, go to your BuildingLink site, click on KeyLink, select Permissions, choose Edit Roles, and tap Yes in the Emergency Key Fob column to enable the red fob as an emergency fob and then you're done.

Please note the red fob should only be registered to a single user of Management Level or higher and stored in a secured location along with the manual override key(s) for manual access when needed. In case of a power outage, please use the provided manual override key (small regular silver key) for each drawer to access your key system manually. Please refer to our KeyLink FAQ section for more information.

QUESTION

What happens in case of a power outage?

ANSWER

In the event of a power outage, where the KeyLink application is unavailable, you can still pull keys for your residents.

To do this, you will need to unlock the drawer from the back with the manual override key that comes with each drawer. Please check with the manager/staff at the building to see where the emergency manual override key is currently stored at for your drawer(s).

Use the back-up flash drive device (plugged into the KeyLink PC) with a working laptop to pull a list of your Map of Drawer(s) to access keys manually. Or, log in to the BuildingLink website via your smartphone or device, click the Other tab on the left, click the KeyLink tab, then choose the Map of Drawers tab. This map will show you the locations of all the keys in the drawer(s). Alternatively, you can contact someone on your team that's offsite and has power and Internet that could pull the Map of Drawers for you, or give our office a call at 877-501-7117 ext. 0 or email us at support@buildinglink.com and someone on call will assist as soon as possible.

QUESTION

My drawer is not opening and closing properly – what do I do?

ANSWER

Ninety-five percent of the time, this is a sign that the drawer has come slightly off the track. To correct the issue, the drawer must be removed from the track and placed back in. Open the drawer, and then lift the black release levers on both sides of it. This will allow the drawer to disengage from the track. (The drawer will still be attached via a cable; there's no need to disconnect this.) While the drawer is disengaged, fully extend both of the tracks, then place the drawer back onto the track. You will have to manually slide both sides of the track towards the front of the drawer to lock it back into place. Once both sides are locked in, try closing the drawer again. This usually fixes the issue.

QUESTION

I've registered my fingerprint but I'm being told I don't have permission to take out a key.

ANSWER

Before a user can access the system, they must be granted permissions to do so on the main BuildingLink website by a security officer. To grant a user access to KeyLink, log into your BuildingLink web site, click the Other tab on the left side of the screen and select KeyLink. Choose the Permissions tab up top. You will see a list of all your employees; click the Edit Roles button on the far right side next to the employee you wish to grant access to. Check off the KeyLink Roles (Admin, Register/Unregister Keys, Remove/Return Keys and View Reports) you wish to grant and click the Update button to finish. Then, on the KeyLink app dashboard, click the Sync to BuildingLink button and the user will be able to use the KeyLink system.

QUESTION

My fingerprint reader works for some people and not others.

ANSWER

This is due to dry skin. A small trick to make the reader work is to rub your finger down the side of your nose before using the reader. Try it, it works! A little grease goes a long way. Another hint is to register a middle or ring finger, as these tend to be less dry.

QUESTION

My fingerprint reader isn't working.

ANSWER

First, make sure the Fingerprint Reader is selected by clicking Administration, then Device Configuration and Diagnostics. You will see a dropdown menu for the fingerprint reader. Make sure it is selected. If it is, unplug the fingerprint reader from the USB hub and plug it into a different port. Restart the KeyLink application and try again.

QUESTION

My webcam isn't working.

ANSWER

Make sure the Connector service is running. Look for a white C in a red hexagon by your system time. Double click this and make sure there are no red exclamation points in it. If there aren't, make sure the correct Webcam is selected by clicking Administration, then Device Configuration and Diagnostics. You will see a dropdown menu for the webcam. Make sure it is selected. If it is, unplug the webcam from the USB hub, plug it into a different USB port, restart the KeyLink application, and try again.

QUESTION

My signature pad isn't working.

ANSWER

Make sure the Connector service is running. Look for a white C in a red hexagon by your system time. Double click this and make sure there are no red exclamation points in it. If there aren't, make sure the signature pad is selected by clicking Administration, then Device Configuration and Diagnostics. You will see a dropdown menu for the signature pad. Make sure it is selected. If it is, unplug the signature pad from the USB hub, plug it into a different USB port, restart the KeyLink application, and try again.

QUESTION

My drawer's red light is flashing, and the screen says Disconnected.

ANSWER

Unplug the drawer from the USB hub and plug it into a different USB port. You can also try powering the drawer off and back on, restarting the KeyLink application, or restarting the PC to reenable connectivity to the drawer.

QUESTION

My software is frozen and I can't click anything.

ANSWER

Because KeyLink runs in Fullscreen mode, it can sometimes be difficult to close the program if it happens to freeze. To close the program, press CTRL ALT DELETE at the same time on your keyboard. Choose Task Manager from the options listed. Once the task manager opens, click the Applications tab, select KeyLink, and choose End Task or press the Windows key on your keyboard. This will open the start menu. From here you can restart the PC.

QUESTION

How can I pull keys if the KeyLink system is down?

ANSWER

In the event of a system failure where the KeyLink application is unavailable, you can still pull keys for your residents. To do this you will need either an Emergency Keyfob or the Emergency Release key for the lock in the back of the drawer. Either of these will open the drawer as long as it has power. If the drawer has no power, the Keyfob will not work. Logon to the Buildinglink website, click the Other tab on the left, click the KeyLink tab, then choose the Map of Drawers tab. This map will show you the locations of all the keys in the drawer. The map is updated whenever you remove, register, or add a key as long as the system is online.

QUESTION

The system cannot find a key that we know is in there.

ANSWER

Unfortunately there are times where a key will not register when placed into a slot. This can be because the key wasn't fully inserted into the slot, the slot did not read the key correctly, or a few other reasons. To ensure a key is returned properly, listen for the audible beep and also check the screen to ensure it reports that a key was returned. To find a missing key, open the drawer by clicking on the drawer's icon on the left side of the screen. Authenticate with your login or fingerprint. Open the drawer. On the screen you will see an option to light up all keys in the system, as well as an option to light up all empty slots. If you choose to light up all keys in the system, missing keys will not light up. If you choose to light up all empty slots, missing keys will light up.

QUESTION

I use the same machine for BuildingLink and KeyLink and I keep having issues with the webcam and signature pad not working in one application.

ANSWER

Only one application can use the hardware connected to the system at any given time. If BuildingLink and KeyLink try to use the hardware at the same time, it can result in the camera or signature pad not working at times. We have found the best way to prevent this is to ensure that when you are not working in BuildingLink, you go back to the dashboard screen. Leaving the event log open has been known to cause issues.

QUESTION

One of the slots on the KeyLink drawer will not read any Keytags.

ANSWER

Call us for a rowboard replacement.

QUESTION

How many keys can we fit on a Keytag?

ANSWER

4 normal sized keys will fit on a tag. Larger keys such as car keys will limit the amount of keys per tag.

QUESTION

We do not have room for the All-in-One PC to fit on our desk. Can we install KeyLink onto our existing computer?

ANSWER

KeyLink can be installed on ANY PC running Windows 7, 8, or 10 64-bit PC.

QUESTION

What is the Emergency Keys button for?

ANSWER

When registering a key, you have the option to designate the key as an Emergency Key. When the Emergency Keys button is pressed, all Emergency Keys will light up to be removed. This can be especially helpful in an emergency where you need to pull out all of your management building keys at once (IE: Front Door Key, Side Door Key, Pool Key, Elevator Key, Lighting Key, etc.)

QUESTION

What is the Temporary Keys button for?

ANSWER

Temporary keys are exactly that, keys that will be in the system temporarily. When registering a new key, you have the option to designate a key as a temporary key. The first time a temporary key is removed from the system, it is automatically unregistered from KeyLink. This can be useful if you need to hold a key for a resident for a short period of time, then return it to them permanently. This works especially well in conjunction with our smart boxes.